

TECHNICAL DRAWING

Chapter V : Pictorial Drawing

Isometric – Oblique – Perspective

Mr. ZENNADI Karim

ENP

May 20, 2026

- 1 Introduction
- 2 Isometric Drawing
- 3 Oblique Projection
- 4 Perspective Projection

Section 1

Introduction

- 1
- 2 Isometric Drawing
- 3 Oblique Projection
- 4 Perspective Projection

1

- ▶ In orthographic projection, the front view or top view taken separately gives an **incomplete idea** of the object. Even experienced engineers can be puzzled when studying the orthographic projection of complicated parts.

- ▶ In orthographic projection, the front view or top view taken separately gives an **incomplete idea** of the object. Even experienced engineers can be puzzled when studying the orthographic projection of complicated parts.
- ▶ To avoid this confusion, **pictorial projection** is the best method to show an object in **one view only**.

- ▶ In orthographic projection, the front view or top view taken separately gives an **incomplete idea** of the object. Even experienced engineers can be puzzled when studying the orthographic projection of complicated parts.
- ▶ To avoid this confusion, **pictorial projection** is the best method to show an object in **one view only**.
- ▶ Pictorial projection represents the three-dimensional shape of an object in a single view that indicates **length**, **breadth** and **height** simultaneously.

An object is more easily visualised from a pictorial projection than from its orthographic projection. Pictorial projections are divided into:

- 1 **Isometric projection**

An object is more easily visualised from a pictorial projection than from its orthographic projection. Pictorial projections are divided into:

- ① **Isometric projection**
- ② **Oblique projection**

An object is more easily visualised from a pictorial projection than from its orthographic projection. Pictorial projections are divided into:

- ① **Isometric projection**
- ② **Oblique projection**
- ③ **Perspective projection**

- In this chapter you will learn about pictorial drawings, with a focus on **Isometric** and **Oblique** drawings.

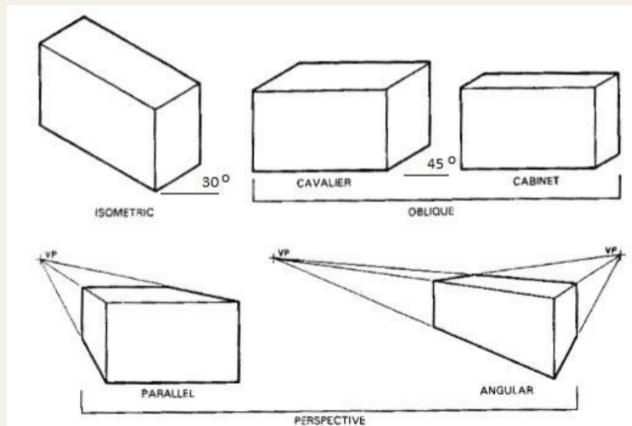

Section 2

Isometric Drawing

- ① Introduction
- ②
- ③ Oblique Projection
- ④ Perspective Projection

2

- ▶ **Isometric projection** shows the three dimensions of a solid in one view, and actual sizes can be **measured directly** from it. Hidden edges are generally not shown.

- ▶ **Isometric projection** shows the three dimensions of a solid in one view, and actual sizes can be **measured directly** from it. Hidden edges are generally not shown.
- ▶ A special isometric grid is required. Both ground lines (Front and Side) are tilted 30° about the horizontal axis.

- ▶ **Isometric projection** shows the three dimensions of a solid in one view, and actual sizes can be **measured directly** from it. Hidden edges are generally not shown.
- ▶ A special isometric grid is required. Both ground lines (Front and Side) are tilted 30° about the horizontal axis.
- ▶ Horizontal lines in the Front, Side, or Top are tilted by 30° in isometric, depending on the direction.

- ▶ **Isometric projection** shows the three dimensions of a solid in one view, and actual sizes can be **measured directly** from it. Hidden edges are generally not shown.
- ▶ A special isometric grid is required. Both ground lines (Front and Side) are tilted 30° about the horizontal axis.
- ▶ Horizontal lines in the Front, Side, or Top are tilted by 30° in isometric, depending on the direction.
- ▶ **Vertical lines remain vertical** — only true vertical lines, not projections of inclined lines.

The principle of isometric projection is illustrated in the figure below.

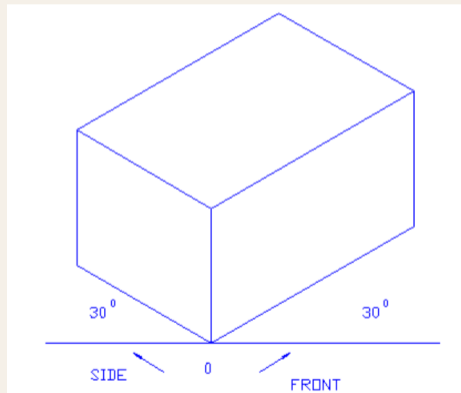

The three orthographic views of a box are shown, with each corner numbered from (0) to (7). Corner (7) is hidden inside the model and is therefore not shown in the isometric view.

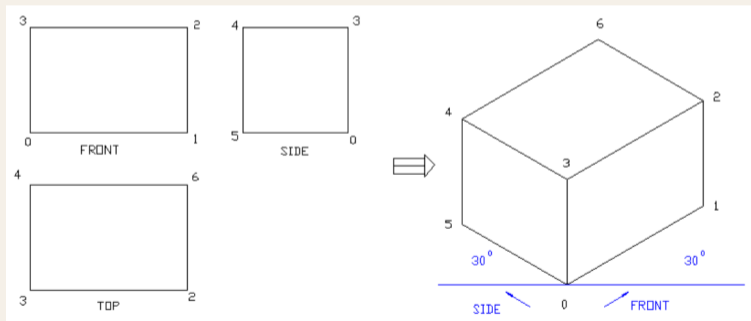

- ▶ A shaped block drawn in conventional isometric projection has **three isometric axes**.
- ▶ These axes are inclined at 120° to each other.

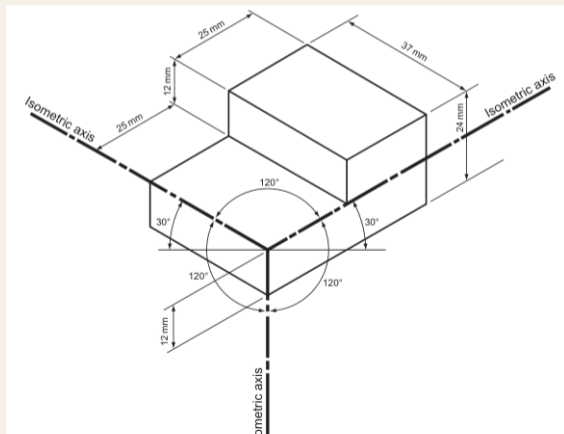

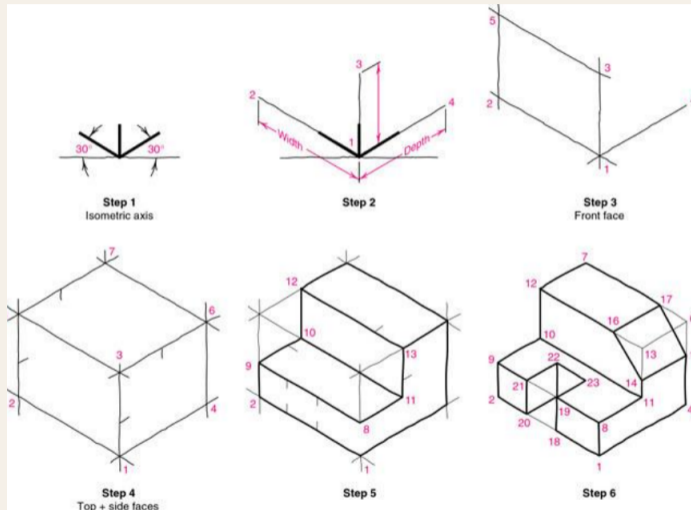

Section 3

Oblique Projection

- 1 Introduction
- 2 Isometric Drawing
- 3
- 4 Perspective Projection

3

- In oblique projection, the **front face** of the object appears in its **true size and shape**, as it is placed parallel to the picture plane.

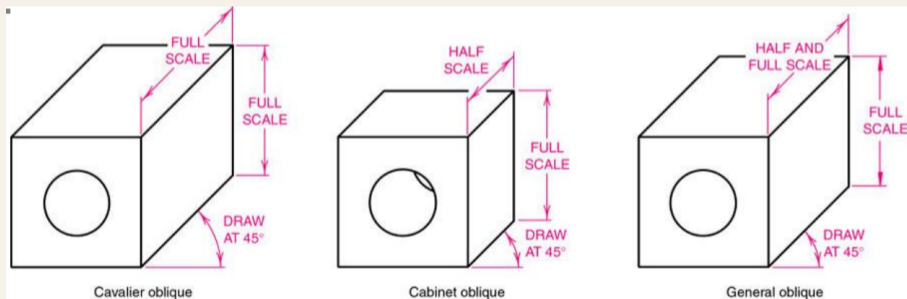

- ▶ In oblique projection, the **front face** of the object appears in its **true size and shape**, as it is placed parallel to the picture plane.
- ▶ The receding lines representing the other two faces are drawn at 30° , 45° or 60° to the horizontal. 45° is the most common practice.

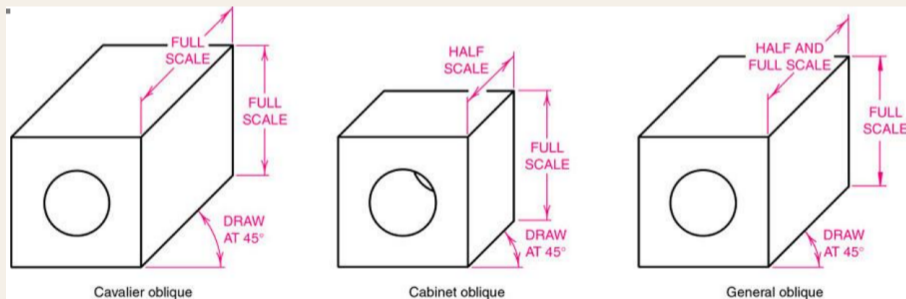

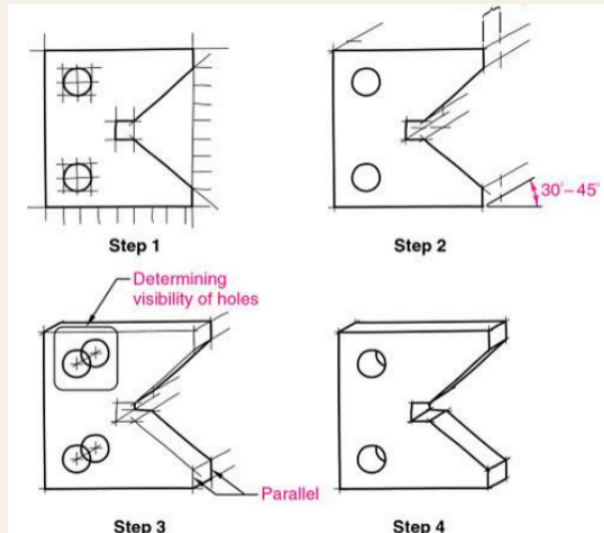

Section 4

Perspective Projection

- 1 Introduction
- 2 Isometric Drawing
- 3 Oblique Projection
- 4**

4

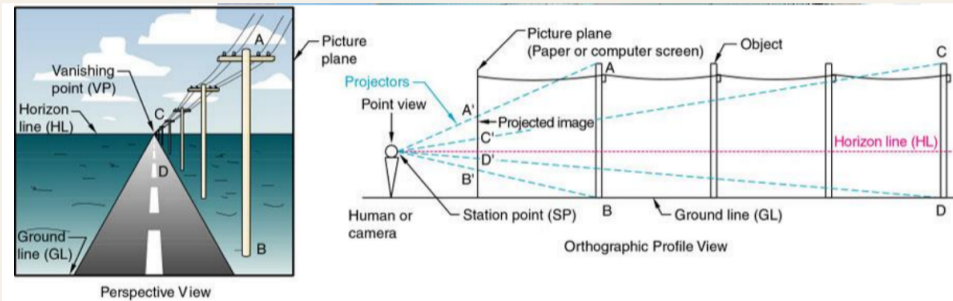

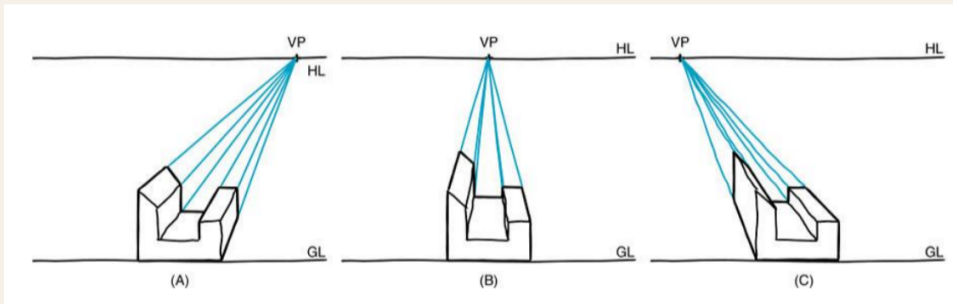

Perspective projections are broadly classified into three categories:

- 1 **Parallel perspective** — single-point perspective

Perspective projections are broadly classified into three categories:

- ① **Parallel perspective** — single-point perspective
- ② **Angular perspective** — two-point perspective

Perspective projections are broadly classified into three categories:

- ① **Parallel perspective** — single-point perspective
- ② **Angular perspective** — two-point perspective
- ③ **Oblique perspective** — three-point perspective

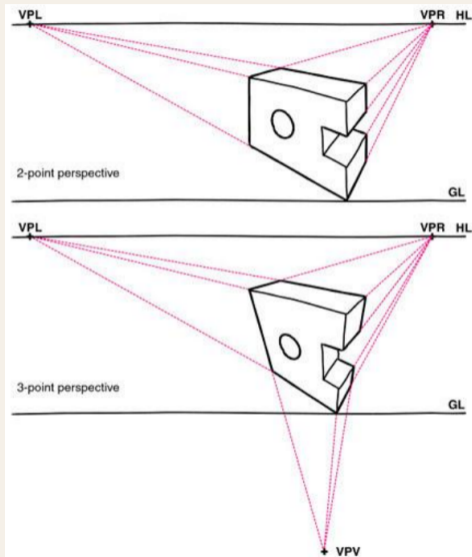

Thank you for your attention.

Mr. ZENNADI Karim – ENP